

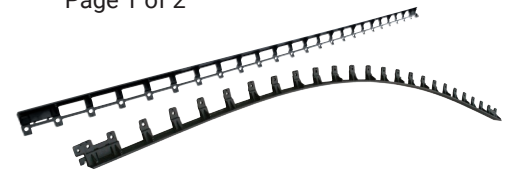

**GATOR EDGE RIGID & FLEX**  
TDS Revision Date (dd/mm/yyyy): 08/05/2025



# TECHNICAL DATA SHEET

**Update:** May 8, 2025  
Make sure you have an updated data sheet on hand.  
Canada and U.S. dial 1-855-847-7767 or (450) 624-1611

**Description:** **Gator Edge Rigid & Flex** are made with 100% Polypropylene Co-Polymer. This will give it great strength as well as provide great flexibility. We have a **Rigid** model which is ideal for straight applications and the **Flex** model that can be used for all curved applications such as walkways, paths, entrances etc. Both the **Rigid and Flex** can be locked together with the “**Twist & Lock**” system. Finally the **Rigid** could be transform in a partial **Flex** by cutting the bridge support between each triangular angles.

- Features:**
- The **Flex** can connect to the **Rigid**.
  - Use a “**Twist & Lock**” connection system.
  - Will not corrode.
  - Easy-to-use.
  - Available in **Flex** or **Rigid** edges.
  - Xtra versatile.
  - Xtra robust system.
  - Xtra support strength.
  - UV resistant.
  - Comes in 8-ft lengths.
  - Use with [Gator Nails](#).
  - Use [Gator Base Screws](#) in [Gator Base](#) application.

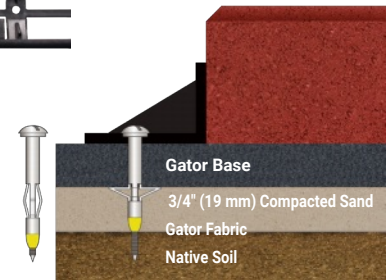

**For use on:** **GATOR EDGE** is an excellent choice to help define alleys, driveways or sidewalks. **GATOR EDGE** is designed for straight or curved installation. It is especially easy to use and quick to install.

## INSTALLATION INSTRUCTIONS:

- Step 1** It can be installed either before or after the paver installation.
- Step 2** Use **10” Gator Nail**. Use one 10” Gator Nail every second hole and at every “**Twist & Lock**” junction, this will ensure continuous lateral support. Ensure edges are installed firmly against the pavers on a minimal compacted structural aggregate base of 6” (15 cm) deeper and wider on all sides than the paved area.
- Step 3** Using **Gator Base Screws**. When using [Gator Base](#), use [Gator Base Screws](#) at every second hole and every “**Twist & Lock**” junction to ensure continuous lateral support. Ensure edges are installed firmly against the pavers. The [Gator Base](#) must be 6” (15 cm) wider on all sides than the paved area.

**Packaging:**

**Product**

- Gator Edge Flex**
  - 1 piece = 8 linear feet
  - 1 Mini-pack = 6 pieces = 48 linear feet
  - 1 Master-pack = 4 Mini-packs = 192 linear feet
  - 1 pallet = 28 Master-packs = 5,376 linear feet
- Gator Edge Rigid**
  - 1 piece = 8 linear feet
  - 1 Mini-pack = 6 pieces = 48 linear feet
  - 1 Master-pack = 4 Mini-packs = 192 linear feet
  - 1 pallet = 28 Master-packs = 5,376 linear feet



**Alliance Designer Products Inc.**  
1800 Berlier st., suite 200, Laval, Quebec, Canada H7L 4S4  
Tel.: 450 624-1611 Fax : 450 624-1622 Toll free : 1 866-212-1611  
www.alliancegator.com - Email : info@alliancegator.com



**GATOR EDGE RIGID & FLEX**

TDS Revision Date (dd/mm/yyyy): 08/05/2025

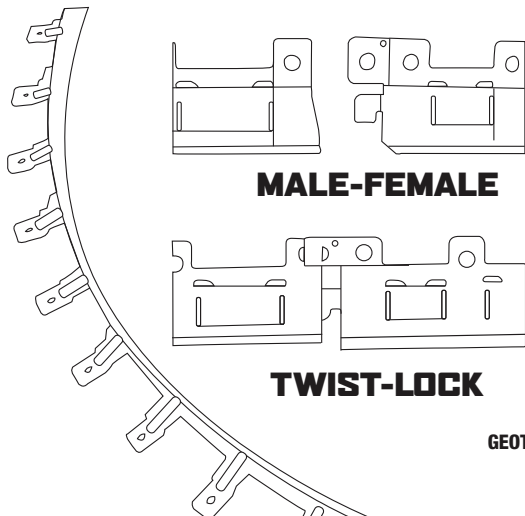
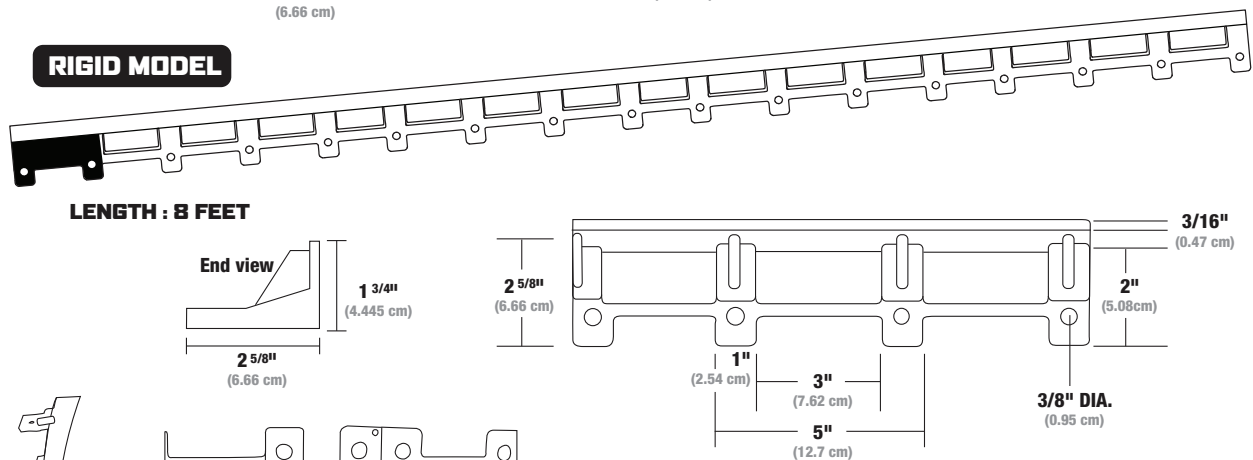
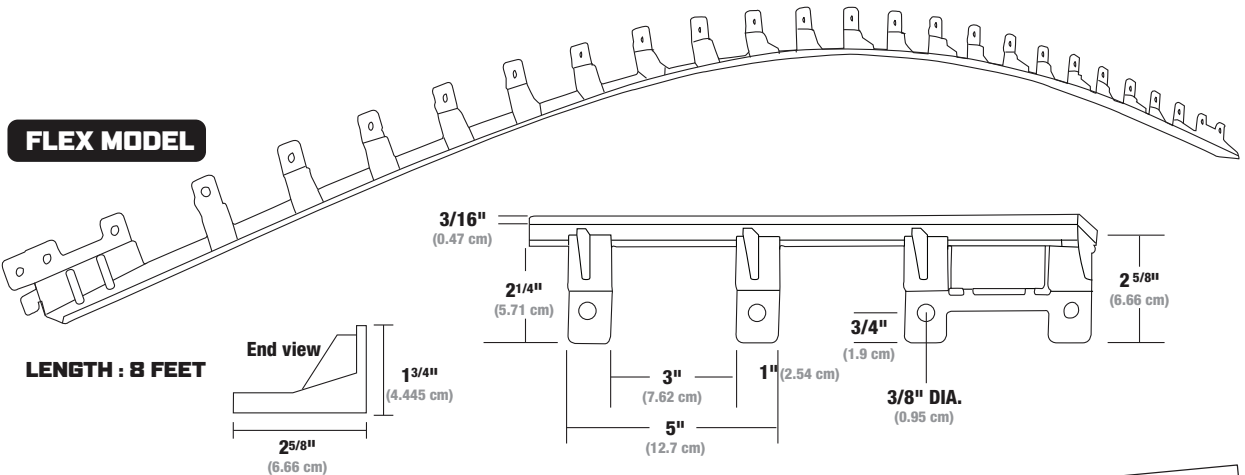
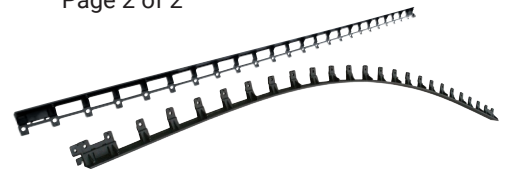

**BEDDING SAND**  
maximum of 1 inch (2.5 cm)

**POLYMERIC SAND**

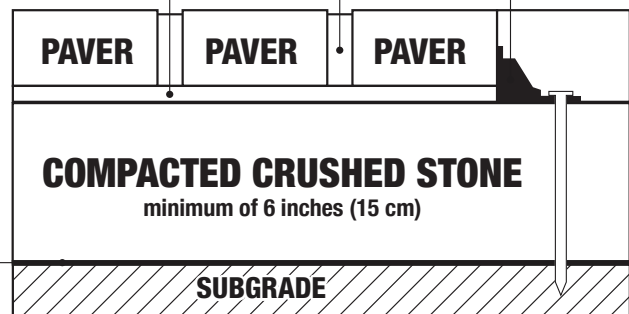

- Gator Edge is:
- Height 1 3/4"
  - Width 2 5/8"
  - Length 8'

**GATOR EDGE FLEX CAN CONNECT TO GATOR EDGE RIGID**

SEE THE INSTALLATION VIDEO  
ON [ALLIANCEGATOR.COM](http://ALLIANCEGATOR.COM)



Alliance Designer Products Inc.  
1800 Berlier st., suite 200, Laval, Quebec, Canada H7L 4S4  
Tel.: 450 624-1611 Fax : 450 624-1622 Toll free : 1 866-212-1611  
[www.alliancegator.com](http://www.alliancegator.com) - Email : [info@alliancegator.com](mailto:info@alliancegator.com)